

# **DINGS' Voice Coil Series**

## **Product Introduction**



# JIANGSU DINGS'



## Jiangsu DINGS' Headquarters

- Founded in 2008 | Changzhou, China (Listed on BSE)
- In-house development and manufacturing of precision motion & actuator solutions
- Global R&D and manufacturing infrastructure
- Global presence in Korea, USA, Japan, and Europe
- Thailand manufacturing facility
- 370 employees worldwide
- Annual revenue: USD 55M (USD 95M consolidated)

# Solution Lineup

From standalone units to modules and stages for diverse applications



**Voice Coil Motor · Actuator · Flat Type**

## Basic Linear Drive

- Direct drive structure
- Fast response
- Flexible design



**Analog Linear Hall Sensor Type**

## Sensor Feedback Drive

- Position feedback
- Stable operation
- Easy control



**Voice Coil Module**

## Integrated Module

- Guide & sensor integrated
- Precise positioning
- Modular design

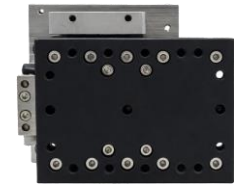

**Voice Coil Stage**

## Precision Positioning Stage

- High-speed response
- $\mu\text{m}$ -level positioning
- For precision equipment

# Voice Coil Motion Demo

Live Motion Demonstration of VCM / VCA / Stage



Voice Coil Motor & Module  
[With High-Precision Linear Encoder]

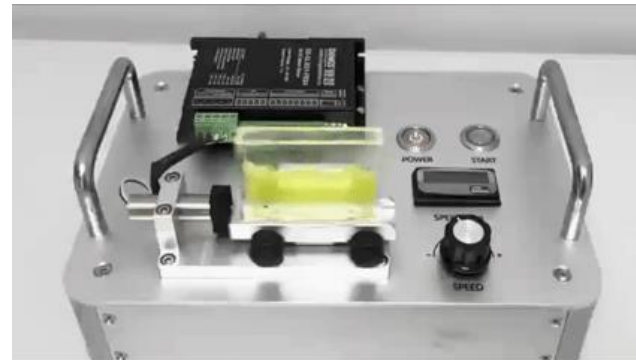

Voice Coil Actuator



Voice Coil Stage  
[With High-Precision Linear Encoder]

# Voice Coil Motor (VCM)

Direct drive linear motion with high precision and fast response

A Voice Coil Motor (VCM) generates linear motion through the interaction between current and magnetic field. As a direct drive system, it converts electrical energy directly into motion without mechanical transmission, making it ideal for high-speed and high-precision positioning.

The operating principle is based on Ampere's force law, where thrust is generated by the current flowing through the coil within a magnetic field.

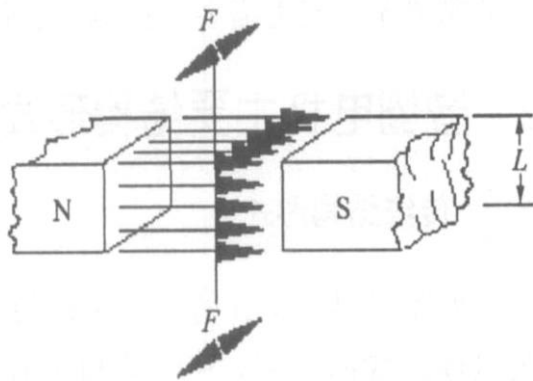

$$F = NIBL$$

- F: Force (N)
- N: Number of coil turns
- I: Current (A)
- B: Magnetic flux density (T)
- L: Length of conductor (m)

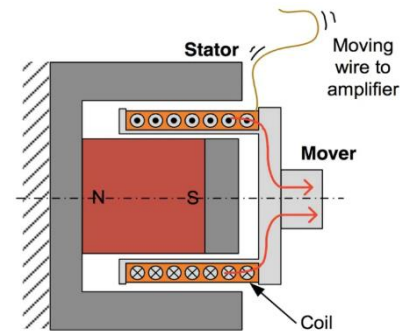

Coil Drive

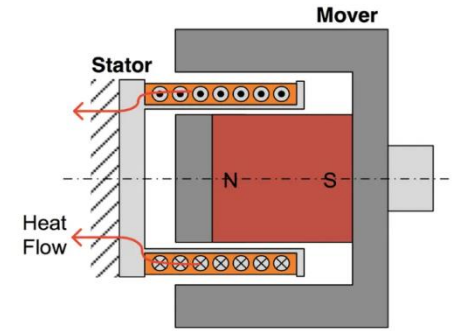

Magnet Drive

# Dual-Shaft Linear Voice Coil Actuator

Voice Coil Actuator (VCA) for high-response, high-precision linear motion

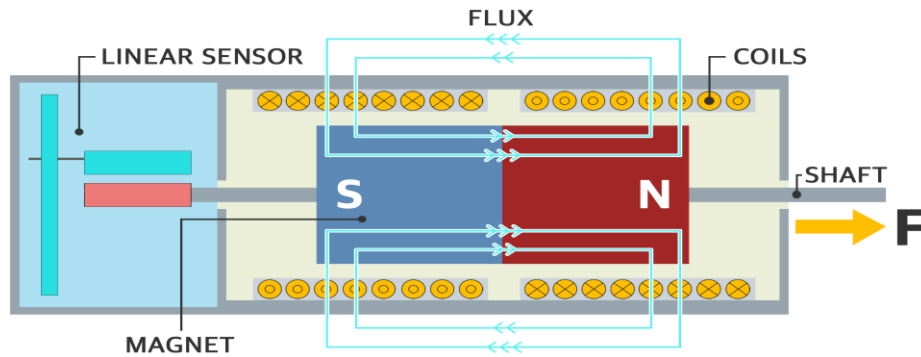

## Operating Principle

A Voice Coil Actuator generates electromagnetic force from the current flowing through the coil, enabling precise linear shaft motion. Its direct drive structure ensures fast and accurate positioning.

## Key Structural Features

With a special magnet array and moving magnet design, it achieves higher thrust within the same compact volume. Its dual output shaft structure also supports simultaneous bidirectional motion.

## Structure

- ① Surface-treated conductive housing
- ② Internal coil assembly
- ③ Magnet mover assembly
- ④ Output shaft
- ⑤ Sliding bearing

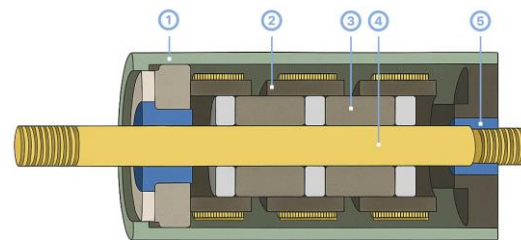
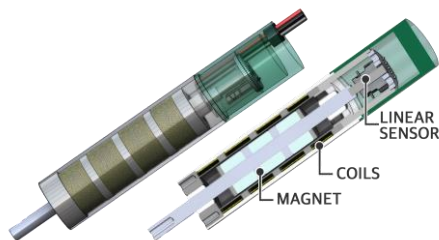

# Product Overview

## Voice Coil Motor Series [Standard Type]



### Key Features

- Low friction · low resistance
- Fast response · high resolution
- Long service life · over 70 million cycles

### Applications

- Semiconductor pick-and-place / Precision optical stages /
- Laser measurement equipment / Medical devices

## Model Specifications – Ø12.7 mm Cylindrical VCM

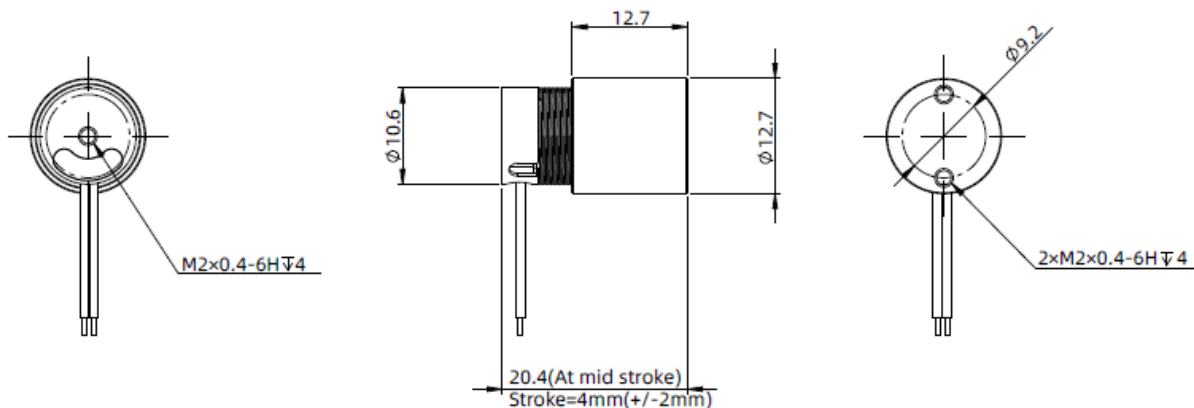

Model	Unit	VC-04-12.7-4
Stroke	mm	4
Continuous Force	N	0.4
Peak Force	N	3.2
Rated Current	A	6.5
Coil Gap	mm	0.38
Temperature Rise	°C	100

# Product Overview

## Voice Coil Motor Series [High Force Type]



### Key Features

High force · High power density  
Wide operating range · Stable force characteristics  
High load · Suitable for high-performance drive applications

### Applications

Industrial automation / Precision drive equipment /  
High-force transfer / Special-purpose machinery

## Model Specifications – Ø45 mm High-Force Cylindrical VCM

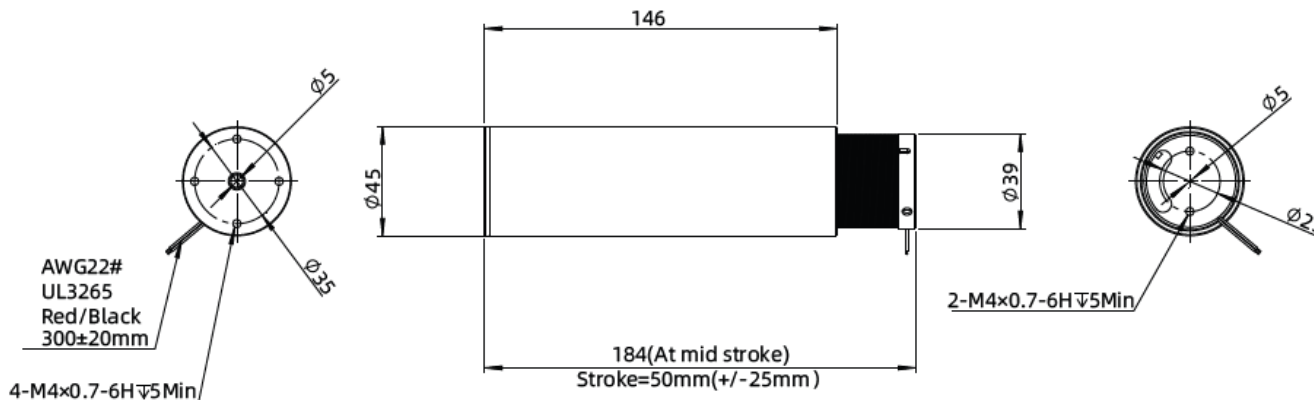

Model	Unit	VCHF-45-50-20-01
Stroke	mm	50
Continuous Force	N	20
Peak Force	N	120
Rated Current	A	1
Coil Gap	mm	0.5
Temperature Rise	°C	100

# Product Overview

## Voice Coil Motor Series [Flat Type]

### Model Specifications – 76 mm Flat VCM

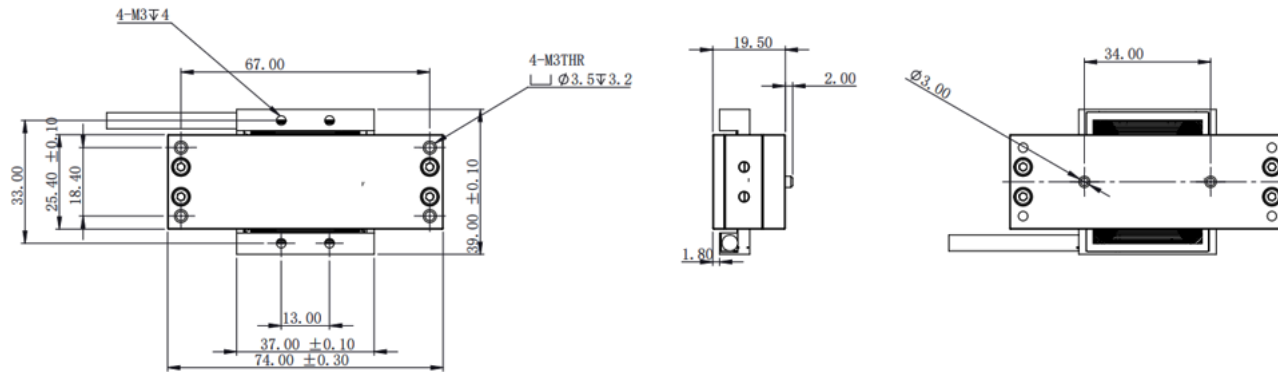

### Model Specifications – 97 mm Flat VCM

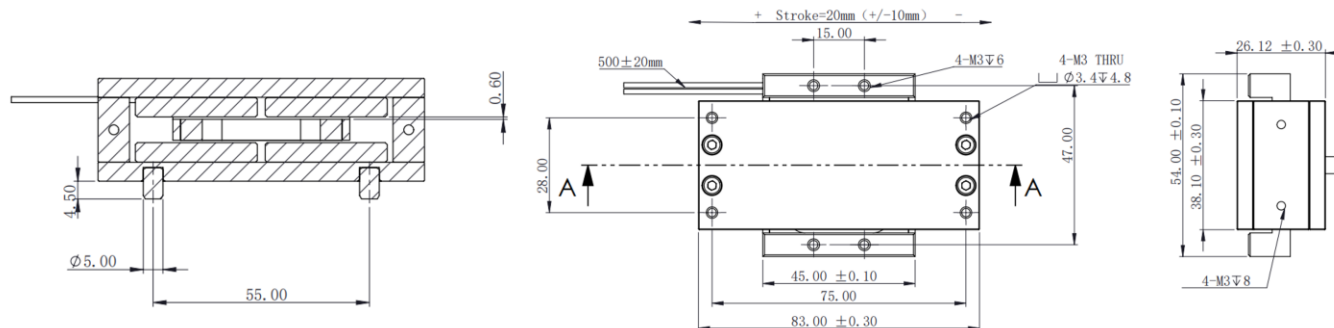

76 mm



97 mm

Model	Unit	VCXR-76-20-3.8-001
Stroke	mm	20
Continuous Force	N	3.84
Peak Force	N	11.5
Rated Current	A	0.85
Coil Gap	mm	0.6
Temperature Rise	°C	155

Model	Unit	VCXR-97-20-11.69-001
Stroke	mm	20
Continuous Force	N	11.69
Peak Force	N	35.1
Rated Current	A	1.4
Coil Gap	mm	0.6
Temperature Rise	°C	155

# Product Overview

## Voice Coil Actuator Series [Standard Output Shaft]



### Key Features

Integrated spring structure · Optimized bearing design  
High response · High-precision motion  
Stable repeatability · Suitable for system integration

### Applications

Medical devices / Semiconductor equipment /  
Industrial automation / Beauty devices

## Model Specifications – Ø13.2 mm Cylindrical VCA

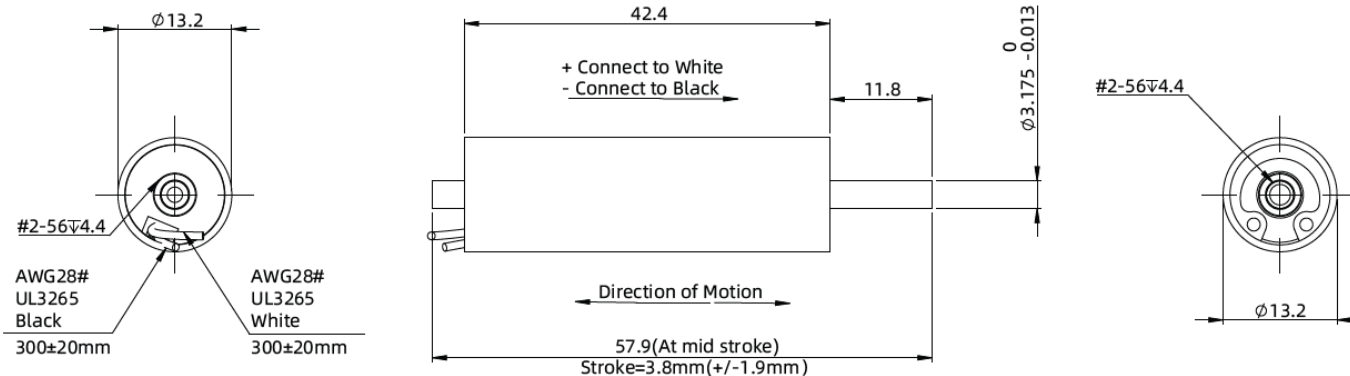

Model	Unit	VC (A) - 13.2-3.8-2.2-01
Stroke	mm	3.8
Continuous Force	N	2.2
Peak Force	N	6.7
Rated Current	A	0.7
Coil Gap	mm	0.4
Temperature Rise	°C	100

# Product Overview

## Voice Coil Actuator Series [Integrated Position Sensor]



### Key Features

Low friction · Zero hysteresis  
 High response · High performance  
 Long service life (>70 million cycles) · Stable repeatability

### Applications

Ventilators / Inhalation & exhalation valve actuation /  
 Precision flow control / Stable repeatability

## Model Specifications – Ø40 mm Ventilator VCA

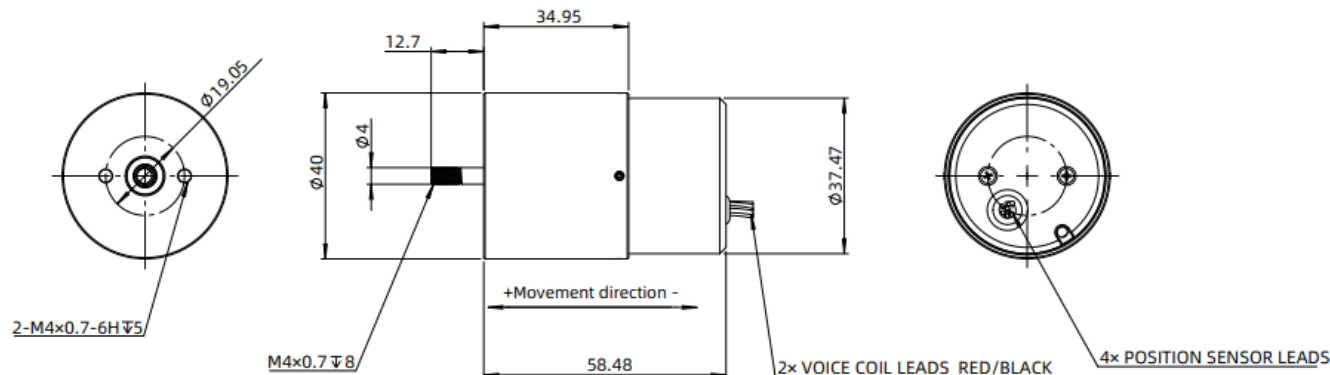

Model	Unit	VC - 40-6.09-17 - PS - 01
Stroke	mm	6.09
Continuous Force	N	17
Peak Force	N	85
Rated Current	A	1.4
Coil Gap	mm	0.5
Temperature Rise	°C	100
Position Sensor Accuracy	mm	0.01

# Product Overview

## Voice Coil Actuator Series [Encoder-Integrated Type]

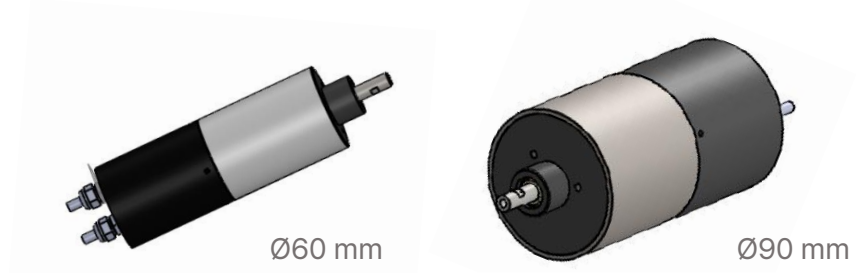

### Model Specifications – Ø60 mm Encoder-Integrated VCA (1 µm resolution / Cable-protected type)

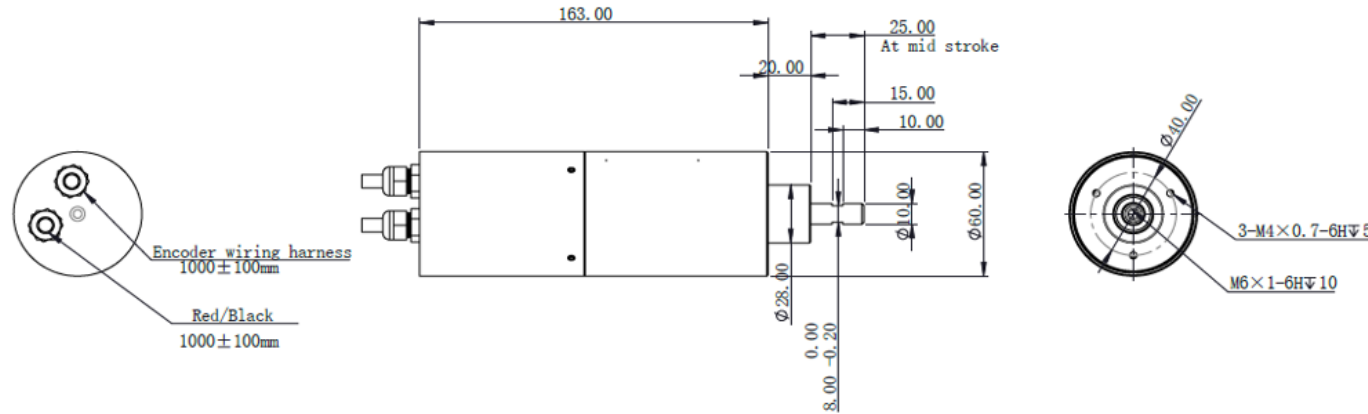

Model	Unit	VC-60-15-40-PS-001
Stroke	mm	15
Continuous Force	N	40
Peak Force	N	142
Rated Current	A	2
Coil Gap	mm	0.7
Temperature Rise	°C	155
Encoder Resolution	µm	1

### Model Specifications – Ø90 mm Encoder-Integrated VCA (1 µm resolution / Cable-protected type)

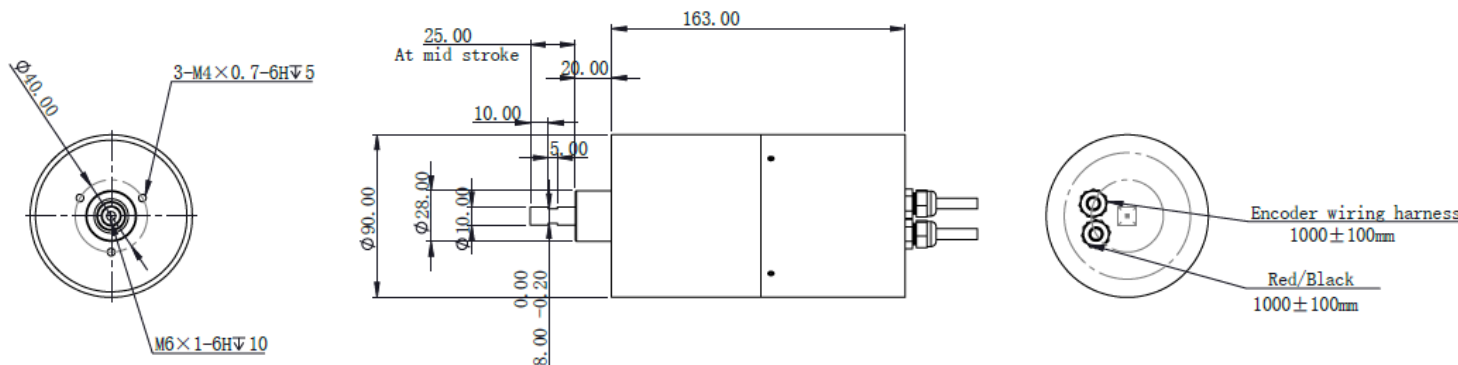

Model	Unit	VC-90-15-90-PS-001
Stroke	mm	15
Continuous Force	N	90
Peak Force	N	340
Rated Current	A	4
Coil Gap	mm	0.7
Temperature Rise	°C	155
Encoder Resolution	µm	1

# Product Overview

## VCHF Solenoid Series [Proportional Valve Solenoid]



<b>Key Features</b>	Low friction · Compact · High-force design High response · Precision control High pressure resistance · High durability
<b>Applications</b>	Proportional control valves / Flow control / Industrial automation / Semiconductor equipment

## VCHF-200 AC Series [AC Voice Coil Motor for Gas Compression]



<b>Key Features</b>	High response · High-force drive Air bearing design High-frequency operation (>100 Hz)
<b>Applications</b>	Gas compression systems / Industrial automation / High-speed precision systems

# Product Overview

## Voice Coil Motor Module Series [Custom Type]

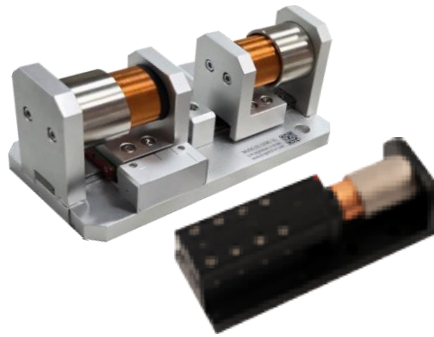

### Key Features

Position feedback control · Positioning accuracy up to  $\pm 0.1 \mu\text{m}$   
Smooth motion control based on direct drive  
Compatible with linear encoders and limit sensors  
High-rigidity module configuration with CRB integration

### Applications

Semiconductor pick-and-place / Precision optical stages /  
Laser measurement equipment / Medical devices  
  
Suitable for high-speed, high-precision positioning systems /  
Available in single-shaft and dual-shaft configurations

# Product Overview

## Voice Coil Motor Module Series [Custom Type]

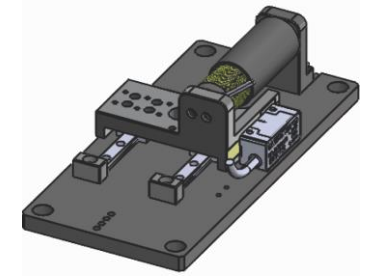

Ø24 mm

### Model Specifications – Ø24 mm VCM Module with Home/Limit Sensors and High-Precision Linear Encoder

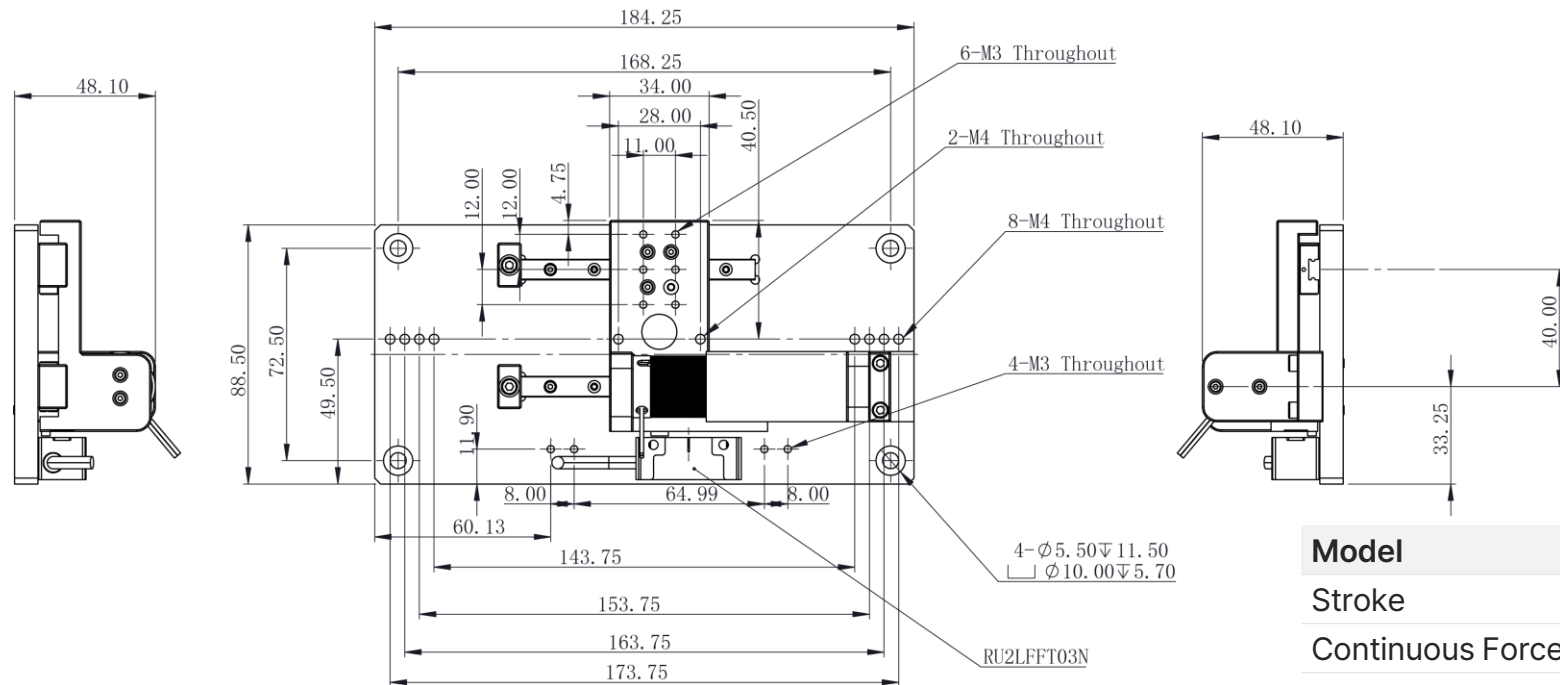

Model	Unit	VC-24-30-2-002-DM
Stroke	mm	30
Continuous Force	N	2
Peak Force	N	19
Rated Current	A	0.85
Coil Gap	mm	0.4
Temperature Rise	°C	155
Encoder Resolution	µm	0.1

# Product Overview

## Voice Coil Motor Module Series [Custom Type]

### Model Specifications – Ø60 mm Speed-Drive VCM Module with Return Force Compensation Spring

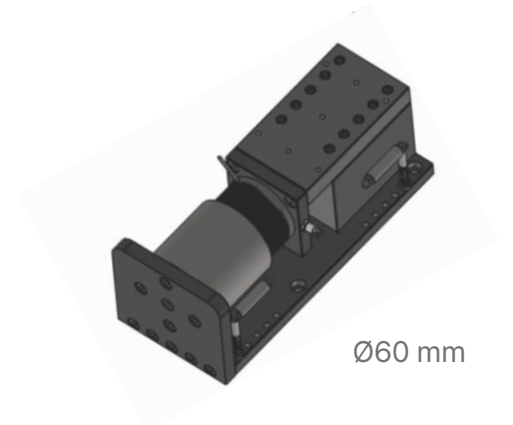

Ø60 mm

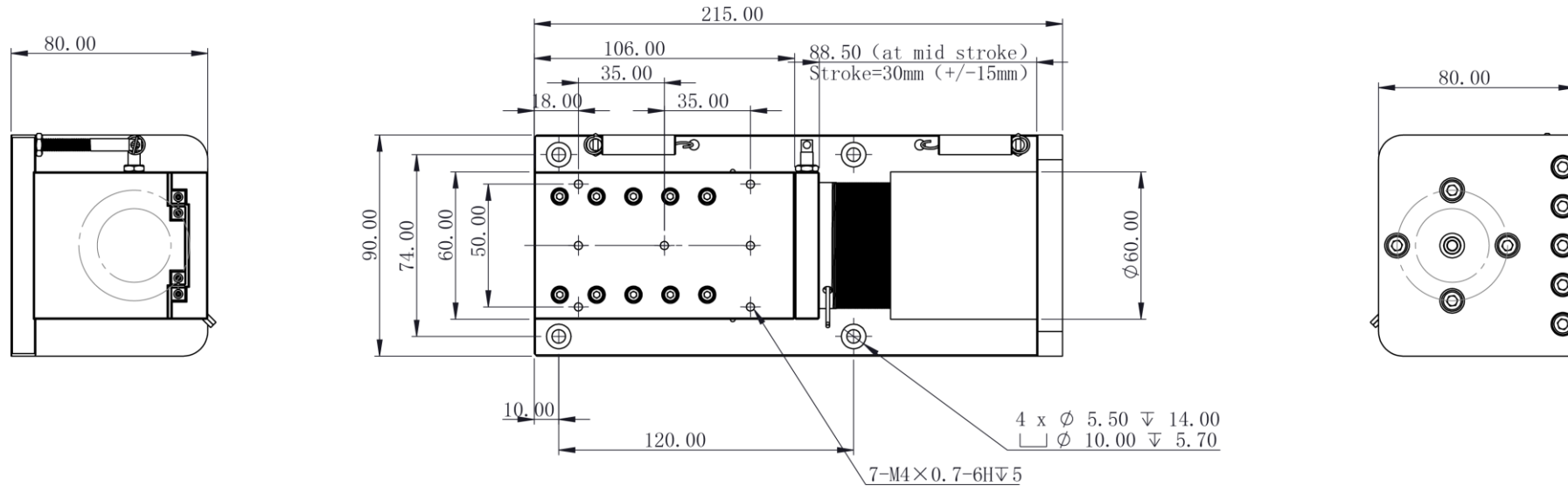

Model	Unit	VC-60-30-20-001-DM
Stroke	mm	30
Continuous Force	N	20
Peak Force	N	82.3
Rated Current	A	1.7
Coil Gap	mm	0.6
Temperature Rise	°C	155

# Product Overview

## INV Series [High-Precision Voice Coil Stage]



### Key Features

High-speed response · Short settling time  
 Low friction · Precision linear motion  
 μm-level positioning · Encoder feedback

### Applications

Semiconductor / Electronics / Optical alignment /  
 Bio / Medical / Precision manufacturing equipment

## Model Specifications – Ø76 mm INV Stage

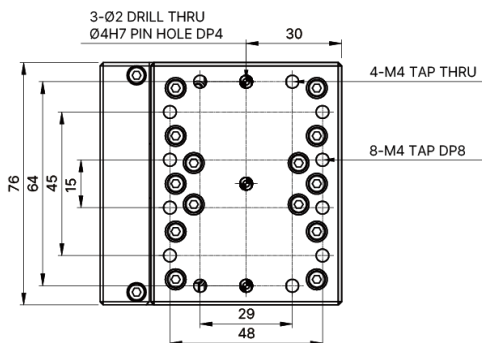

[Top View]

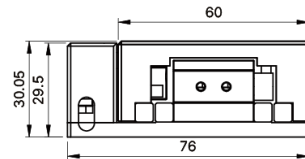

[Front View]

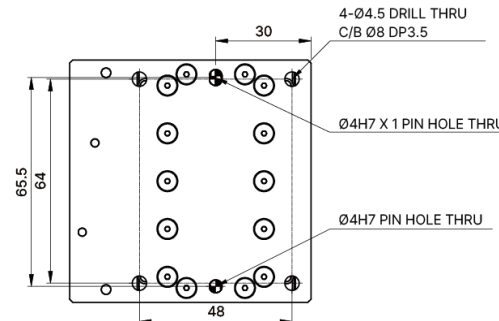

[Bottom View]

Model	Unit	INV76-B20-10S4-C050-A1
Stroke	mm	20
Continuous Force	N	3.84
Peak Force	N	11.5
Encoder Resolution	μm	0.1
Repeatability	μm	±0.5
Straightness	μm	±2.5
Flatness	μm	±2.5

# Voice Coil Series – Integrated Drive Solution with Welcon

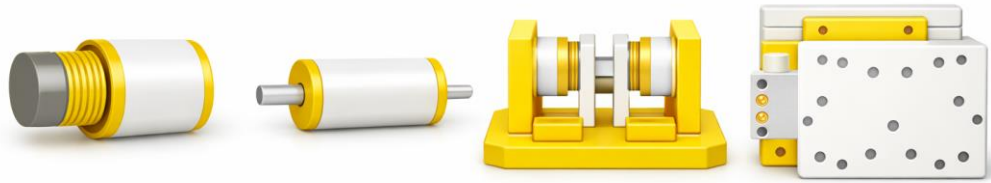

Optimized for the DINGS' Voice Coil Series, Welcon drives support PWM (Open Loop), Linear Hall Sensor, and Encoder-based Closed Loop control within a unified platform.

welcon SYSTEMS



**PIXIE**  
Compact & Low-current precision control

12 – 48 VDC (H/W Limit : 10 ~ 60VDC)

DC / BLDC / VCM / PMSM (Rotary or Linear Type)

1A / 3A (Peak to Peak) \*

3A / 6A (Peak to Peak) \*

EtherCAT, CAN, USB

72mmX 44.3mmX 30mm / 90g



**FALCON**  
Flexible control & integration

12 – 48 VDC

DC / BLDC / VCM / PMSM (Rotary or Linear Type)

1A / 2A / 5A \*

2A / 4A / 10A \*

EtherCAT, CAN, USB

106.5mm X 78mm X 25mm / 200g



**MERLIN**  
High-power control for advanced systems

12 – 48 VDC

DC / BLDC / VCM / PMSM (Rotary or Linear Type)

5A

10A

EtherCAT, CAN, USB

103mm X 62mm X 30.8mm / 190g

# Voice Coil & Drive Solution Platform

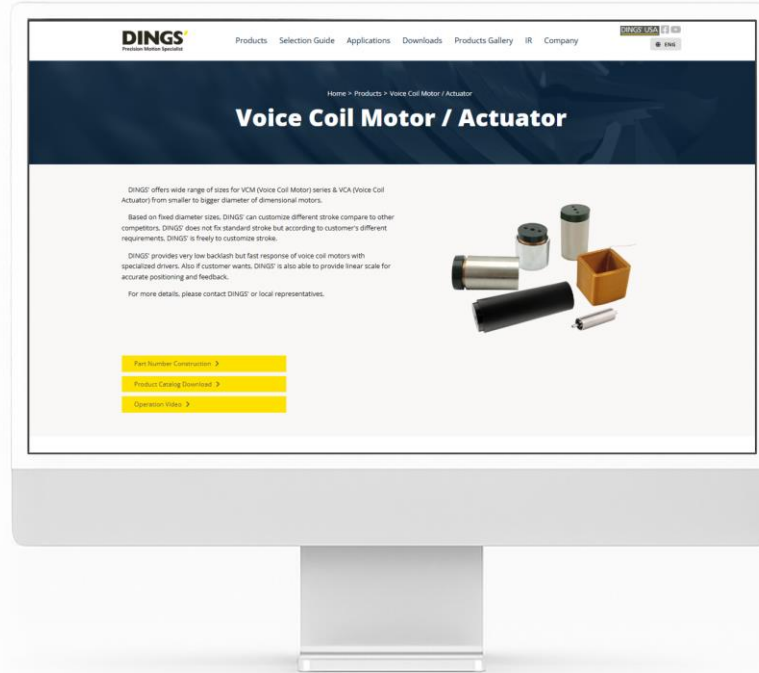

## DINGS' Voice Coil Motors & Actuators

High-response, high-precision linear motion solutions



## DINGS Korea Partner Solution – Welcon Drive

Integrated drive and control platform for VCM applications

# THANK YOU



[www.dingsmotion.com](http://www.dingsmotion.com)

Jiangsu DINGS' Intelligent Control Technology